

DELTA PACK 80x50

PISTON PUMP – CONDENSATE REMOVAL SYSTEM



2014 NOVELTY

The new Delta Pack 80x50 mm adopts softened line, in a pure white colour, co-ordinated with the latest wall-mounted air conditioning units.

This pack is easier than ever to fit. It includes the new Si-10 UNIVERS'L incorporating the latest Sauermann® technology with proven reliability and all the elements required for a complete installation.

MAIN ADVANTAGES

• Attractive

- Smoothened lines for elbow – Sleek duct design.
- Colour: RAL 9010 (pure white).
- Flush fitting of all parts, with discreet clip tabs.
- Mates with the wall-mounted air-conditioning unit via a rubber gasket that fits the A/C side perfectly.

• Silent installation

- Silent pump operation: 22 dBA.
- Elbow fitted with exclusive 'High Energy Absorbing Foam', allowing fitting on movable office partitions as well.
- The discharge tube is insulated right up to the false ceiling (anti-vibration and anti-condensation).

• Easy installation

- Ready-to-fit kit including all accessories useful for fitting.
- Intuitive elbow positioning.
- Plastic parts are easy to adjust irrespective of wall type (brick, concrete, etc.).
- Optimised space for refrigeration connection pipes Ø max. 1/4" - 1/2" insulated.
- "Drain Safe Device" facilitates connection to the discharge pipe.

• Rapid pump maintenance

- Unpluggable power cord.
- Transparent, removable tank.

• Proven reliability

- Sauermann Inside® : Exclusive technology.
- No filter. Designed to allow free passage of particles up to 2 mm.
- High flow: 20l/h, shorter running time.
- Longer life due to the additional use of gravity draining thanks to the "Drain Safe Device" when the pump is stopped.

KIT CONTENT

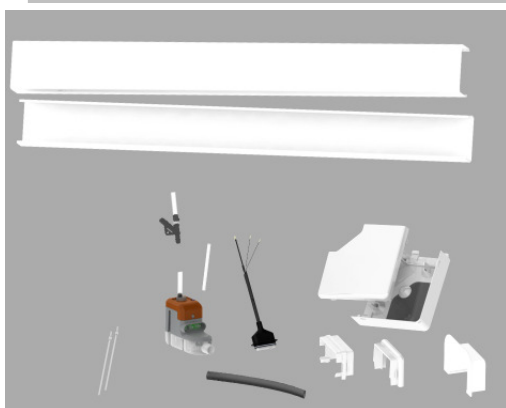

- Si-10 UNIVERS'L piston pump with:
 - Built-in detector.
 - Transparent PVC tube int. Ø 6mm – L: 1 m, foam-insulated over 800 mm, fitted with a "Drain Safe Device" (ACC0216).
 - 1.5 m unpluggable power cord: 2 power wires, 2 safety contact wires.
- 2-part elbow (base and cover).
- 750 mm duct.
- Ceiling fitting (covers hole in false ceiling).
- Elbow/Duct gasket.
- Rubber Elbow/Split gasket.
- 500 mm flexible hose - int. Ø 15 mm (connects to split).
- Vent pipe.
- 6 screws and plugs for fixing duct and elbow.
- 2 pipe clamps.

APPLICATIONS

Air-conditioning wall units
(connection pipes Ø max 1/4" – 1/2" insulated)



TECHNICAL SPECIFICATIONS

Max. flow rate	20 l/h
Max. discharge head	10 m (4l/h)
Max pressure	14 m (0l/h)
Sound level at 3.3ft (1m) according to EN ISO 3744 (Measured at LNE lab, pump operating with water, out of application)	22 dBA
Sound level at 3.3ft (1m) (Measured at Sauer mann lab, pump operating with water)	≤ 25 dBA
Mains supply	230 V ~ 50/60 Hz - 14 W
Isolation class	<input type="checkbox"/> (double isolation)
Detection levels	ON: 18mm, OFF: 13mm, AL: 21mm
Safety switch	NF 8 A resistive - 250 V
Thermal protection (overheating)	194 °F - 90 °C (automatic restarting)
Operating Cycle	30%: 3s ON – 7s OFF
Protection	IPX4
Colour	RAL 9010 – pure white
Elbow dimensions (LxWxH)	130 x 130 x 50 mm
Duct dimensions (LxWxH)	750 x 80 x 50 mm
Tubing	Ø max : 1/4" – 1/2" isolated (max 6,5 kW)
Safety standards	CE
RoHS directive	Conform
DEEE directive	Conform
Packaging	1.55 kg – L763 x W225 x H62 mm
Masterpack	10 pieces

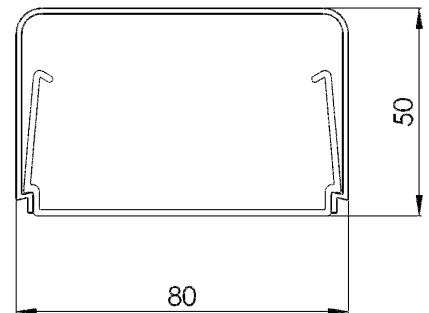
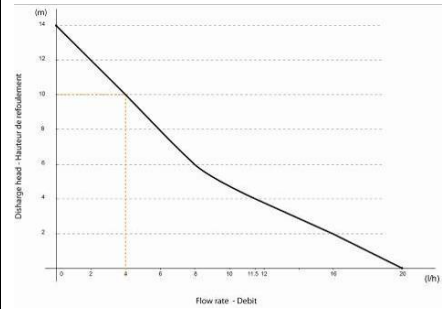

ACTUAL FLOW RATES (l/h)

Discharge head	Total tube length Øint 6 mm			
	5 m	10 m	20 m	30 m
0 m	20	19	18	17
2 m	16	15	14	13,5
4 m	11,5	11	10,5	10
6 m		8,5	7,5	6,5
8 m		6	5	4
10 m		4	3,5	2,5

RECOMMENDED ACCESSORIES



Clear PVC hose
Øint. 6mm (1/4")
ACC 00105 : 5m
ACC 00150 : 50m



Self-sealing fitting for drain hose
Øint. 1/4" (6mm)
ACC 00205 (x6)