



Sauermann's new Delta Pack 80x60

Pump inside a trunk

**80x60
mm**

Large space
for tubing



Quick and easy
installation

**22
dB(A)**

Low operating
sound level
EN ISO 3744 tested



Patented
piston pump
technology

MAX FLOW RATE
20 L/h
(5 gph)

QUICK FIT & RELEASE
Easy installation - Easy maintenance

DELTA PACK 80x60

Delta Pack 80x60 includes a new elbow design that can be easily opened and maintained.

There is no connection piece connecting the elbow and the straight length of duct.

Art. Nr. Sauermann: DP10CE05UN23

Art. Nr. Sauermann: DP10CE06UN23

It includes the Si-10 UNIVERS'L pump which incorporates the latest in patented piston-pump technology.

Easy installation and maintenance:

- New quick fit and release corner piece: no tools needed.
- One piece pump for easy installation
- The kit content allows for installation versatility.
- Transparent and removable reservoir.
- Translucent hose: easy to track waterflow, build-up, etc.
- Protection film on the elbow: does not get dirty when installed.

Improved design:

- Compact elbow and trunking design that can be easily opened and maintained.
- No connection piece connecting the elbow and the straight length of duct.
- Improved internal space design with increased space for pipework.
- Available in two colours: Brilliant white (RAL 9003) and off white (RAL 9001).

Quiet:

- 22 dBA at full power – independently tested.
- Elbow includes 'High Energy Absorbing Foam' to absorb vibration and sound.
- Anti-vibration and condensate insulation included on discharge line.

Proven reliability:

- Patented pump technology.

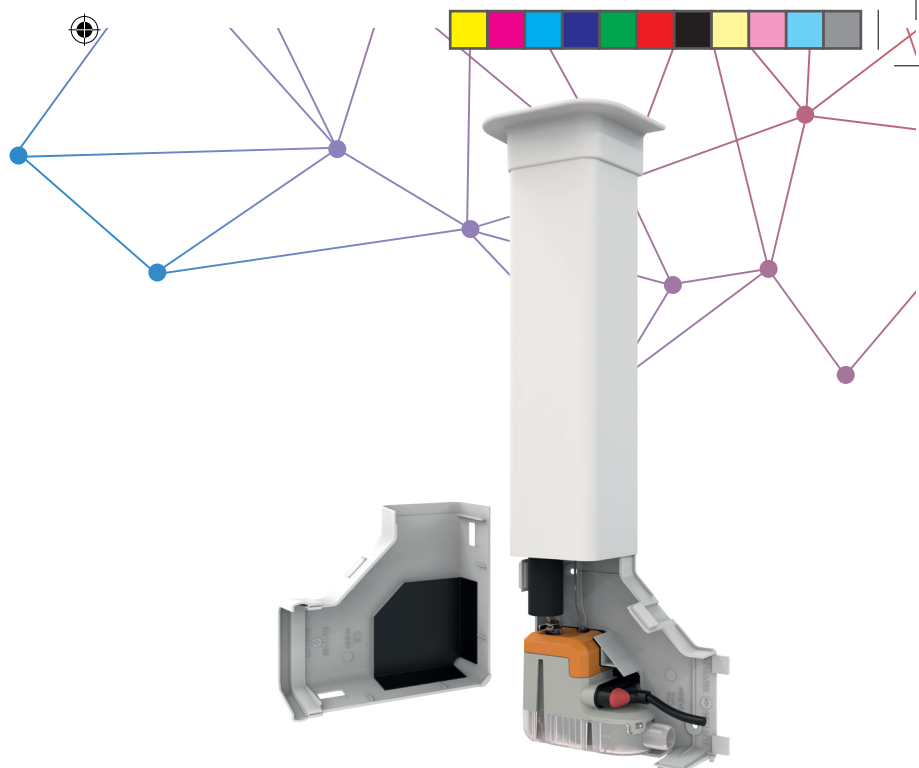

Characteristics

Max. flow rate	20 l/h
Max. discharge head	10 m (Flow rate=4l/h)
Max pressure	14 m (Flow rate =0l/h)
Sound level at 1m according to EN ISO 3744 (Measured at LNE lab, pump operating with water, out of application)	22 dBA
Mains supply	230V~ 50/60Hz - 14 W
Detection levels	ON: 18mm, OFF : 13mm, Safety : 21mm
Safety switch	NC 8 A resistive – 250V
Thermal protection (overheating)	115°C (Auto reset)
Operating conditions	100% - Continuous duty
Protection	IPX4
Colour	DP10CE05UN23 : RAL 9003 signal white (brilliant white) DP10CE06UN23 : RAL 9001 off white (cream)
Elbow dimensions (LxWxH)	130 x 130 x 60 mm
Duct dimensions (LxWxH)	750 x 80 x 60 mm
Lineset	Ø max : 3/8" – 5/8" isolated (Up to 13 kW)

D00JUSDP - 18/07

Sauermann UK
Trident Business Park
7-9 Amy Johnson Way
Blackpool / England / FY4 2RP

Tel : (+44)1253 340170
Fax : (+44) 1253 340179
info.uk@sauermanngroup.com

www.sauermann.co.uk